



INVITATION TO BID

Appliances

Fire Station 48, 4228 Airport Blvd, Arlington WA 98223

The City of Arlington is soliciting bids for appliances to equip the new Fire Station 48 being constructed at 4228 Airport Blvd, Arlington WA 98223. **Bids are due by 2:00 pm on April 12, 2021.** Bids received after such time and date will not be considered. Bids are to be submitted on the attached Bid Form and may be submitted by mail, in person, or by email to:

City of Arlington
Procurement and Contracting
238 N Olympic Ave
Arlington, WA 98223

Debbie Strotz
(360) 403-3429
dstrotz@arlingtonwa.gov

Results of the bid will be posted on the City of Arlington website <http://arlingtonwa.gov> within 24 hours of bid opening. A public opening will not be held. Written technical questions relating to the bid should be directed to Debbie Strotz, Procurement/Contracts Analyst, at the above email address. Written questions will be accepted up to 72 hours before bid deadline.

Bids shall constitute offers to City of Arlington which shall be binding for thirty (30) days from the date of bid opening. City of Arlington reserves the right to reject any bid, any portion of any bid and/or to reject all bids. City of Arlington further reserves the right, but without obligation, to waive informalities and irregularities.

The City of Arlington reserves the right to award the purchase contract ("Purchase Contract") to the lowest responsive, responsible bidder as it best serves the interest of the City. The Bidder to whom the Purchase Contract is awarded shall execute and return the Contract to the City within ten (10) calendar days from the date the Bidder is notified of Notice of Award. Failure of the Bidder to execute the Contract, the Bidder shall be in default, and the City shall have the right to award the Purchase Contract to the next lowest responsive, responsible Bidder.

The City of Arlington, in accordance with Title VI of the Civil Rights Act of 1964, 78 Stat. 252, 42 U.S.C 2000d to 2000d-4 and Title 49, Code of Federal Regulations, Department of Transportation, Subtitle A, Office of the Secretary, Part 21, Nondiscrimination in Federally-Assisted Programs of the Department of Transportation issued pursuant to such Act, hereby notifies all bidders that it will affirmatively ensure that in any contract entered into pursuant to this advertisement, disadvantaged business enterprises as defined at 49 CFR Part 26 will be afforded full opportunity to submit bids in response to this invitation and will not be discriminated against on the grounds of race, color, national origin, or sex in consideration for an award.

BID ITEMS

See Bid Form

All product delivery will be F.O.B. City of Arlington - Fire Station 48, 4228 Airport Blvd, Arlington, WA 98223.

COPIES OF BIDS AND BID PROTESTS

The city will post copies of the bids received at <http://arlingtonwa.gov>. In accordance with RCW 39.04.105, if the City receives a written protest from a Bidder, the City will not execute a contract for the project with anyone other than the protesting Bidder without first providing at least two (2) full business days' written notice of the City's intent to execute a contract for the project; provided that the protesting Bidder submits notice in writing of its protest no later than two (2) full business days following bid opening. Any protest must be made in writing, signed by the protesting Bidder or its authorized agent, and filed with the City's Procurement and Contracting Office, 238 N Olympic Ave., Arlington, WA 98223, with a copy to the City Attorney, Bailey, Duskin & Peiffle, 103 North Street, (PO Box 188), Arlington, WA 98223. The protest shall contain all of the following information:

- a) The protester's name, address, and phone/facsimile number;
- b) The bid number and bid project name;
- c) A detailed description of the specific factual and legal ground(s) for the protest, including all exhibits referenced by the protester; and
- d) The specific ruling and relief requested.

The City reserves the right to reject all bids as a remedy to a protest or independently of protests. Failure to comply with these procedures shall render a protest untimely or inadequate and, consequently, may result in the City rejecting the protest solely on this basis. Any decision made by the City regarding the bid award, contract execution or bid rejection shall be final, subject to such judicial review as permitted under Washington law upon timely filing in the Superior Court of Snohomish County, Washington. This venue clause shall modify any other provision in these Bid Documents to the extent there is an inconsistency.

BASIS FOR AWARD

Bidder shall provide itemized bid including delivery, installation and materials. Bid evaluations will be based on the lowest cumulative bid on Bid Form. Applicable sales tax will be added on invoices (current rate 9.2%), however it will not be used in evaluation of bids.

INSURANCE

1. The delivery of said appliances in accordance with these specifications shall be understood to be the responsibility of the supplier, and the supplier shall maintain adequate insurance coverage to protect the City, its officers, agents, and employees from any claims for damages resulting from the delivery. Prior to delivery, the supplier shall provide proof to the City that it and its subcontractors are insured under a

commercial general liability insurance policy covering the delivery within the scope of this solicitation, in adequate quantity to protect against legal liability arising out of contract activity, but no less than \$2,000,000 per occurrence, \$4,000,000 annual aggregate.

2. In the event that product delivered pursuant to this solicitation involves the use of vehicles, either owned or non-owned by the Supplier and its subcontractors, automobile liability insurance shall be required. The minimum limit for automobile liability is \$2,000,000 per occurrence, using a Combined Single Limit for bodily injury and property damage. The Supplier shall provide proof to the City that it is insured under an automobile liability policy.
3. The Supplier agrees to name the City, its agents, and employees as additional insureds when obtaining liability insurance and to provide an Acord Certificate of Insurance with proof of the Additional Insured endorsement to this effect within fifteen (15) calendar days of the issuance of the Purchase Order. All of the Supplier's policies shall be primary to any other valid and collectible insurance.

ATTACHMENTS

1. Bid Form
2. Sample Purchase Order (PO) with Terms

ADVERTISED

- March 29, 2021 – The Herald
- Online at City of Arlington website: <http://arlingtonwa.gov>

E-MAILED

March 29, 2021 - MRSC Vendor Roster.

Main Category: General Goods

Sub-Category: Appliances – Household Type

FRIGIDAIRE

PROFESSIONAL

FPBG2278UF

FRENCH DOOR COUNTER-DEPTH REFRIGERATOR

22.3 CU. FT.

Smudge-Proof™
STAINLESS STEEL

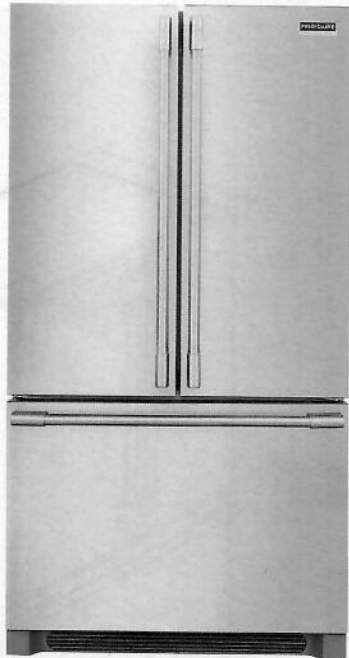

AVAILABLE
COLORS



Stainless

PRODUCT DIMENSIONS

Height (Cabinet Including Hinge)	69-7/8"
Width	36"
Depth (Including Door)	27-1/8"

MORE EASY-TO-USE FEATURES

Smudge-Proof™ Stainless Steel
Resists fingerprints and cleans easily.

Full-Width Deli Drawer

Easily store anything from meats and cheeses to sheet cakes and large platters in our fully-extendable, large capacity deli drawer.

Multi-level LED Lighting

Find fresh foods quickly with bright multi-level LED Lighting.

EvenTemp™ Cooling System

Our EvenTemp™ cooling system keeps food cool without breaking a sweat, distributing air effectively so groceries stay at the right temperature.

SpaceWise® Freezer Organization System

Our SpaceWise® Freezer Organization System keeps frozen foods organized and accessible with deep freezer storage and an adjustable divider.

PureSource Ultra® II Ice & Water Filtration

Remove 99.3% of lead and 99.9% of cysts from your household water with a genuine water filter.

PureAir Ultra® II Air Filter

Fresh air offers great taste. Our PureAir Ultra® II air filters effortlessly keep the food in your refrigerator tasting fresh by removing odor particles with fast-acting, highly absorbent carbon technology.

SIGNATURE FEATURES

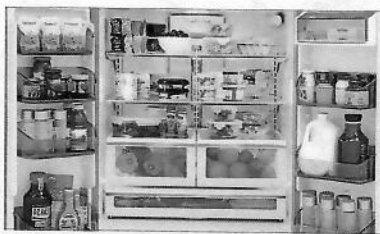

SpaceWise® Organization System

Our SpaceWise® Organization System makes it easy to keep food organized and accessible, with adjustable door bins and shelves that offer storage capacity and flexibility.



CrispSeal™ Crispers

Humidity-controlled CrispSeal™ crispers keep produce fresher longer, so you can waste less and save money.

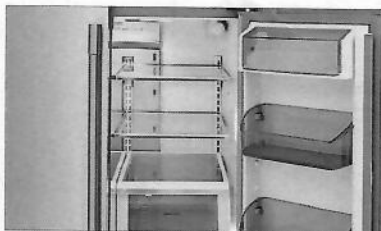

Professional-Grade Design

Durable hardware and professional-grade design features including smoky door bins, door bin liners, edge-to-edge glass shelving with metallic trim, and a distinctive handle lend a high-quality look to your kitchen.



Get a built in look with counter-depth design

Our counter-depth refrigerator gives you the built in look without the remodel, and gives you over 4 inches of kitchen floor space back.

FPBG2278UF

COUNTER-DEPTH FRENCH DOOR REFRIGERATOR

22.3 CU. FT.

FRIGIDAIRE
PROFESSIONAL

FEATURES

Door Design	Square Doors
Door Handle Design	Stainless Steel
Cabinet Finish	Gray
Door Stops / Door Closers	No / Yes
Door Hinge Covers	Hidden
Rollers - Front / Rear	Adjustable / Yes
Energy Saver Plus Technology	
Water Filter Location	Top-Right Fresh Food Section
Sound Package	Quiet Design

DISPENSER

Controls	LED Controls
Dispenser Design	
User Interface Buttons	1" Side Control
Crushed Ice / Cube Ice / Water	
Ice Option / Freeze Option	PowerPlus [®] Ice / PowerPlus [®] Freeze
Display On / Off Option	
Lock / Light	
Temp / Door Ajar / Power Failure Alerts	Yes / Yes / Yes
Water Filter Change Indicator Light	Yes
Air Filter Change Indicator Light	Yes

REFRIGERATOR FEATURES

Lighting	Multi-Level LED
Water Filter Type	PureSource Ultra [®] II
Air Filter Type	PureAir Ultra [®] II
Quarter-Width Fixed Shelves	
Half-Width Fixed Shelves	4
Quarter-Width Sliding Shelves	
Cantilever Shelves	Yes
Full-Width Deli Drawer	1
Wine Rack / Can Dispenser	Yes/No
CrispSeal [™] Crispers with Humidity Control	2
Dairy Compartment	1 Smoky (Right Door)
Gallon Fixed Door Bins	2 Smoky (Door Door)
2-Liter Fixed Door Bins	
Gallon Adjustable Door Bins	4 Smoky
2-Liter Adjustable Door Bins	1 Smoky
Dispenser Bin	
Non-Slip Bin Liner / Bottle Retainers	7 Gray / No

FREEZER FEATURES

Effortless [®] Glide Freezer Drawer	Yes
Sliding Full-Width Freezer Baskets	1
Basket Dividers	2 (Upper and Lower Basket)
Lighting	LED
Automatic Ice Maker	Yes

CERTIFICATIONS

Sabbath Mode (Star-K [®] Certified)	Yes
--	-----

SPECIFICATIONS

Total Capacity (Cu. Ft.)	22.3
Refrigerator Capacity (Cu. Ft.)	15.5
Freezer Capacity (Cu. Ft.)	6.8
Power Supply Connection Location	Right Bottom Rear
Water Inlet Connection Location	Left Bottom Rear
Voltage Rating	120V / 60Hz / 15A
Connected Load (kW rating) @ 120 Volts ¹	1.02
Amps @ 120 Volts	8.5
Minimum Circuit Required (Amps)	15
Shipping Weight (Approx.)	347 Lbs.

¹For use on adequately wired 120V dedicated circuit having 2-wire service with a separate ground wire. Appliance must be grounded for safe operation.

PRODUCT DIMENSIONS

A - Height (Incl. Hinges & Rollers)	69-7/8"
B - Cabinet Width / Door Width	35-7/8" / 36"
C - Depth (Incl. Door)	27-1/8"
Depth with Door Open 90°	42-1/2"
Depth with Drawer Fully Extended (Incl. Handle)	44-7/8"

"BUILT-IN LOOK" CUTOUT DIMENSIONS

Height (Incl. Hinges & Rollers)	70-1/4"
Width	36"
Depth	25"

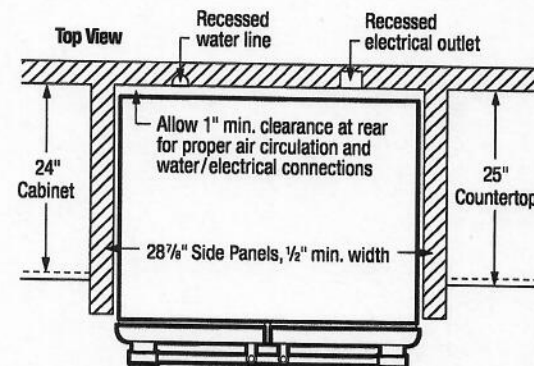
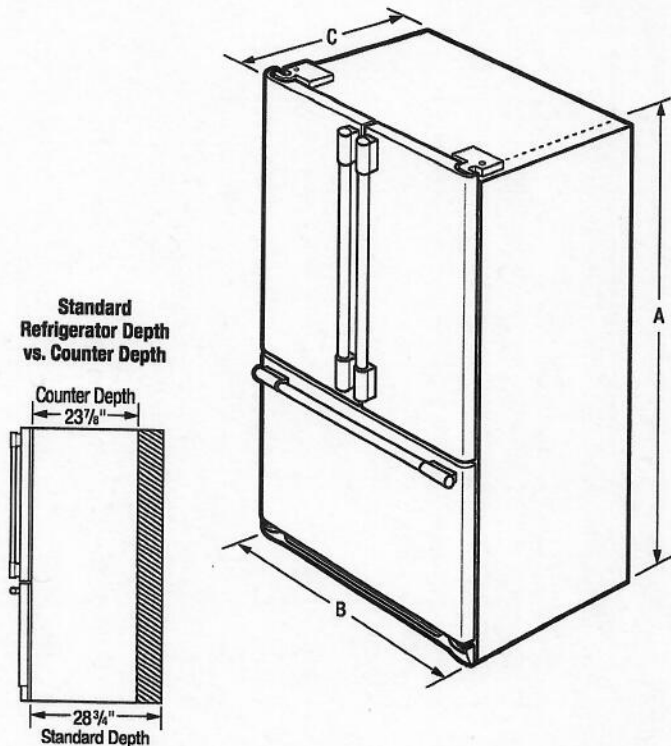

Note: For planning purposes only. Always consult local and national electric, gas and plumbing codes. Refer to Product Installation Guide for detailed installation instructions on the web at frigidaire.com / frigidaire.ca. Specifications subject to change. Accessories information available on the web at frigidaire.com / frigidaire.ca.

FRIGIDAIRE

USA • 10200 David Taylor Drive • Charlotte, NC 28262 • 1-800-FRIGIDAIRE • frigidaire.com
CANADA • 5855 Terry Fox Way • Mississauga, ON L5V 3E4 • 1-800-265-8352 • frigidaire.ca

FPBG2278UF 9/18
©2018 Electrolux Home Products, Inc.

FPBG2278UF
COUNTER-DEPTH FRENCH DOOR REFRIGERATOR
 22.3 CU. FT.

FRIGIDAIRE
 PROFESSIONAL

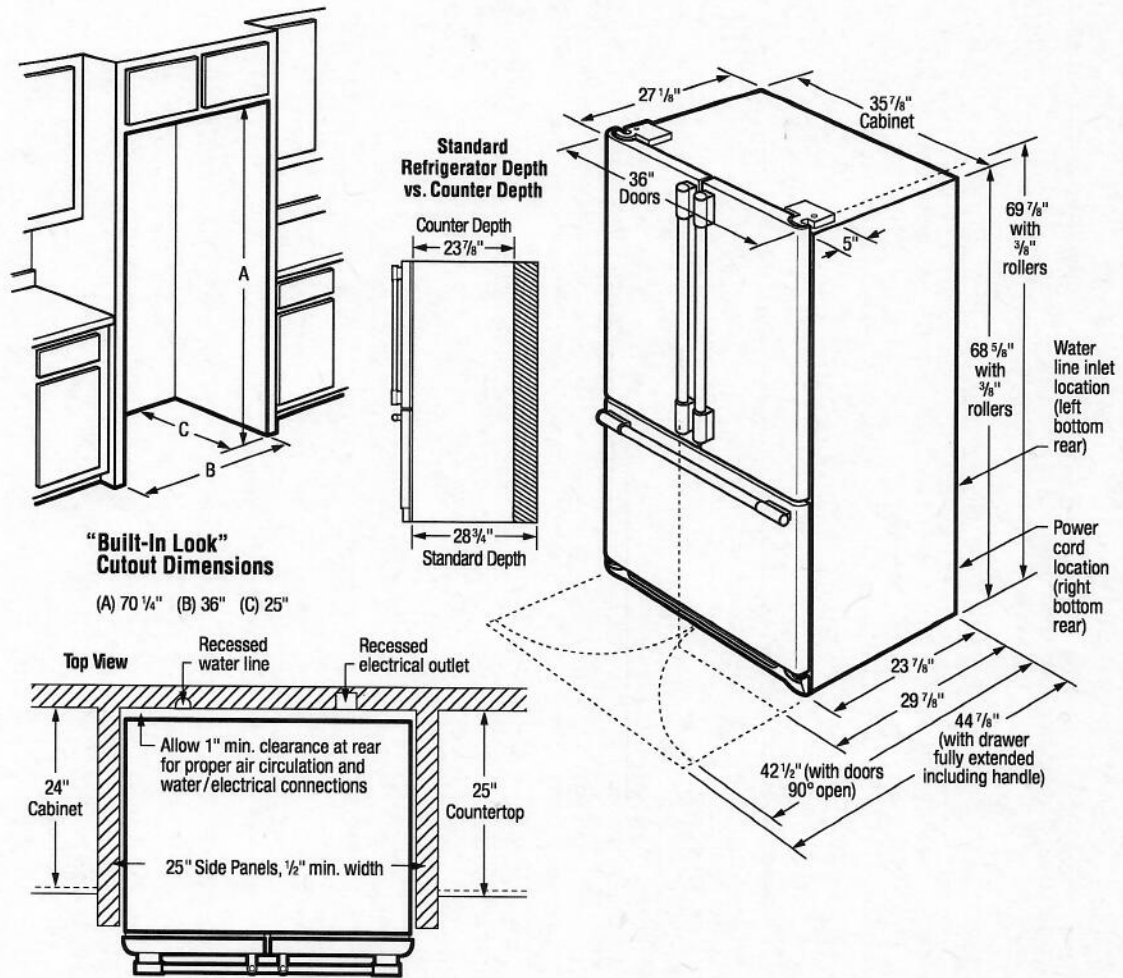

INSTALLATION SPECIFICATIONS

- Product Shipping Weight (approx.) – 347 Lbs.
- An electrical supply with grounded three-prong receptacle is required. The power supply circuit must be installed in accordance with current edition of National Electrical Code (NFPA 70) and local codes & ordinances.
- Voltage Rating – 120V / 60 Hz / 15 Amps
- Connected Load (kW Rating) @ 120 Volts = 1.02 kW
- Amps @ 120 Volts = 8.5 Amps
- Always consult local and national electric & plumbing codes.
- Floor should be level surface of hard material, capable of supporting fully loaded refrigerator.
- Minimum 3/8" clearance required for sides and top of refrigerator or freezer with 1" clearance at rear to allow for ease of installation, proper air circulation, and plumbing / electrical connections.
- When installing refrigerator adjacent to wall, cabinet or other appliance that extends beyond front edge of unit, 20" minimum clearance recommended to allow for optimum 120° to 180° door swing, providing complete drawer / crisper access and removal. (Absolute 4-1/2" minimum clearance will ONLY allow for 90° door swing which will provide drawer / crisper access with

- restricted removal.)
- To ensure optimum performance, (do not install in areas where temperature drops below 55° F or rises above 110° F) and avoid installing in direct sunlight or close proximity to range, dishwasher or other heat source.
- For proper ventilation, front grille MUST remain unobstructed.
- Recess electrical outlet when possible.
- Water recess on rear wall recommended to prevent water line damage.
- Water Pressure – Cold water line must provide between 30 and 100 pounds per square inch (psi).
- Copper or stainless steel tubing with 1/4" O.D. recommended for water supply line with length equal to distance from rear of unit to household water supply line plus 7 additional feet. Optional Water Supply Installation Kits available.
- Adjustable front rollers to assist with door alignment.

"BUILT-IN LOOK" SPECIFICATIONS

- Minimum opening of 70-1/4" H x 36" W x 25" D required to allow for ease of installation, proper air circulation, and plumbing / electrical connections.
- Remove all wall / floor molding prior to installation.



FRIGIDAIRE

USA • 10200 David Taylor Drive • Charlotte, NC 28262 • 1-800-FRIGIDAIRE • frigidare.com
 CANADA • 5855 Terry Fox Way • Mississauga, ON L5V 3E4 • 1-800-265-8352 • frigidare.ca

Note: For planning purposes only. Always consult local and national electric, gas and plumbing codes. Refer to Product Installation Guide for detailed installation instructions on the web at frigidare.com / frigidare.ca. Specifications subject to change. Accessories information available on the web at frigidare.com / frigidare.ca

FPBG2278UF 9/18
 ©2018 Electrolux Home Products, Inc.

FRIGIDAIRE

FFTR2021T D/S/W/B

TOP MOUNT
REFRIGERATOR
20.4 CU. FT. TOP MOUNT



AVAILABLE COLORS



PRODUCT DIMENSIONS

Height (Including Hinges & Rollers)	69"
Width	29-5/8"
Depth (Including Door)	32"

MORE EASY-TO-USE FEATURES

Reversible Door
Door can be installed to open left or right based on your needs.

Clear Dairy Bin
Keep foods like butter, cheese and yogurt organized.

¹Compared to 18 cu. ft. top mount refrigerators.

SIGNATURE FEATURES

Same Width. More Capacity.¹

With a 20 cu. ft. top freezer refrigerator, you can have a refrigerator that fits the same space as an 18 cu. ft. top freezer refrigerator, but get more capacity.

Store-More™ Humidity-Controlled Crisper Drawers

Keep your fruits and vegetables fresh in our humidity-controlled crisper drawers.

Store-More™ Gallon Door Shelf

Door storage gives you room for larger items like a gallon of milk.

Full-Width Wire Freezer Shelf

Gives you a way to organize items in your freezer better so you can find food quickly.

FFTR2021T D/S/W/B TOP MOUNT REFRIGERATOR

20.4 CU. FT.

FRIGIDAIRE

FEATURES

Door Design	UltraSoft™
Door Handle Design	Black Stainless (D), Stainless Steel (S), Color-Coordinated (W/B)
Cabinet Finish (Textured)	Black (D/S), Color-Coordinated (W/B)
Door Stops	Yes
Door Hinge Covers	Black (D/S), Color-Coordinated (W/B)
Door Reverse Option	Yes
Rollers - Front/Rear	Adjustable/Yes
Sound Package	
Toe Grille	Black (D/S), Color-Coordinated (W/B)

REFRIGERATOR FEATURES

Interior Lighting	Standard
Refrigerator Shelves	2 Full-Width Glass
Deli Drawer	1 Half-Width
Wine/Can Rack	
Store-More™ Crisper Drawers	2 Clear
Humidity Controls	2
Dairy Compartment	Clear Dairy Door
Door Bins	
Door Racks	3 Full-Width White
Non-Slip Bin Liner	
Tall Bottle Retainers	
Gallon Door Storage	1

FREEZER FEATURES

Door Bins	
Door Racks	2 Full-Width White
Freezer Shelves	1 Full-Width Wire
Factory Ice Maker w/ Large Ice Bin	Optional (PN # IM16)
Lighting	

SPECIFICATIONS

Total Capacity (Cu. Ft.)	20.4
Refrigerator Capacity (Cu. Ft.)	15.3
Freezer Capacity (Cu. Ft.)	5.1
Power Supply Connection Location	Right Bottom Rear
Water Inlet Connection Location	Bottom Right
Voltage Rating	120V/60Hz
Connected Load (kW Rating) @ 120 Volts¹	0.72
Amps @ 120 Volts	6.0
Minimum Circuit Required (Amps)	15
Shipping Weight (Approx.)	220 Lbs.

¹For use on adequately wired 120V, dedicated circuit having 2-wire service with a separate ground wire. Appliance must be grounded for safe operation.

PRODUCT DIMENSIONS

A-Height (Including Hinges & Rollers)	69"
B-Width	29-5/8"
C-Depth (Including Door)	32"
Depth with Door Open 90°	60"

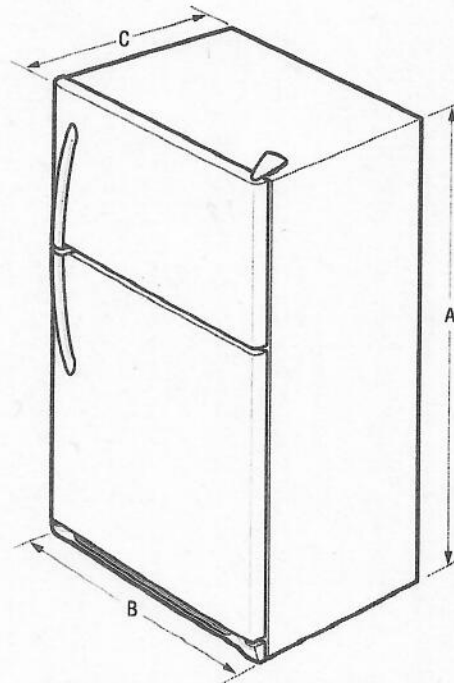

Note: For planning purposes only. Always consult local and national electric, gas and plumbing codes. Refer to Product Installation Guide for detailed installation instructions on the web at frigidaire.com / frigidaire.ca.

Specifications subject to change. Accessories information available on the web at frigidaire.com / frigidaire.ca

FRIGIDAIRE

USA • 10200 David Taylor Drive • Charlotte, NC 28262 • 1-800-FRIGIDAIRE • frigidaire.com
CANADA • 5855 Terry Fox Way • Mississauga, ON L5V 3E4 • 1-800-265-8352 • frigidaire.ca

FFTR2021T 10/17

© 2017 Electrolux Home Products, Inc.

FFTR2021T D/S/W/B TOP MOUNT REFRIGERATOR

20.4 CU. FT.

FRIGIDAIRE

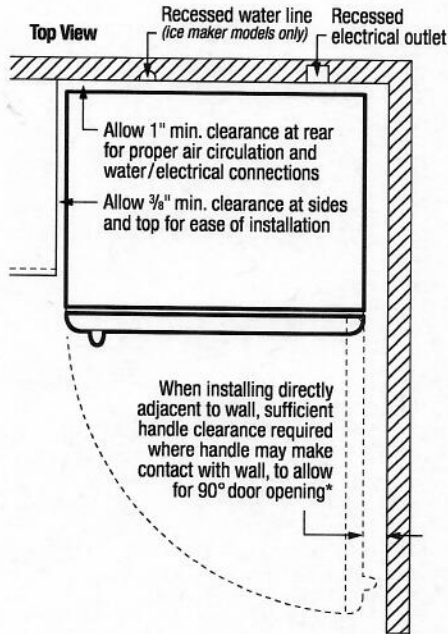

*When installing refrigerator adjacent to wall, cabinet or other appliance that extends beyond front edge of unit, 20" minimum clearance recommended to allow for optimum 140° door swing, providing complete crisper access and removal. (Absolute 3" minimum clearance will ONLY allow for 90° door swing which will provide limited crisper access with restricted removal.)

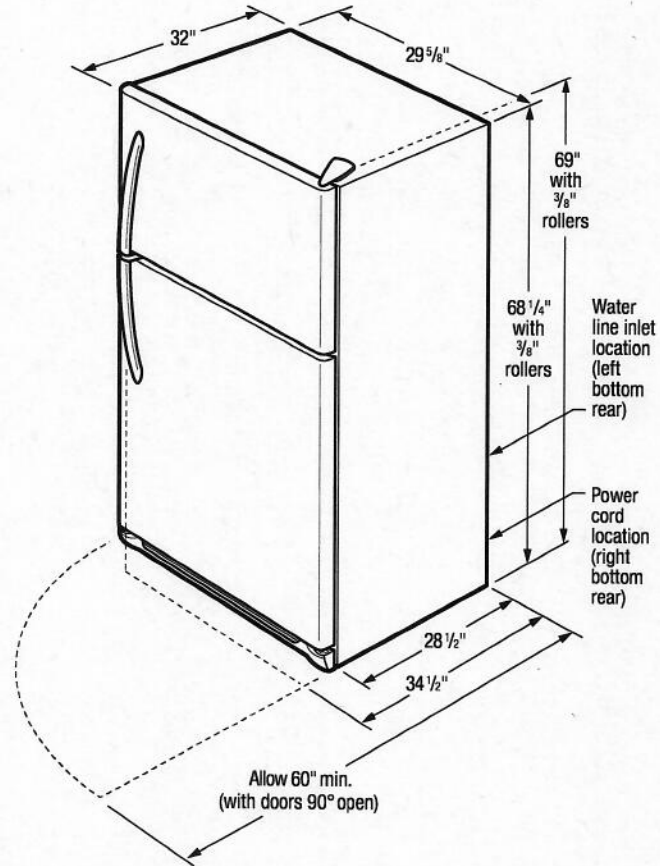

INSTALLATION SPECIFICATIONS

- Product Shipping Weight (approx.) - 220 Lbs.
- An electrical supply with grounded three-prong receptacle is required. The power supply circuit must be installed in accordance with current edition of National Electrical Code (NFPA 70) and local codes & ordinances.
- Voltage Rating - 120V/60 Hz
- Connected Load (kW Rating) @ 120 Volts = 0.72 kW
- Amps @ 120 Volts = 6.0 Amps
- Always consult local and national electric & plumbing codes.
- Floor should be level surface of hard material, capable of supporting fully loaded refrigerator.
- Minimum 3/8" clearance required for sides and top of refrigerator with 1" clearance at rear to allow for ease of installation, proper air circulation, and plumbing/electrical connections.
- When installing refrigerator adjacent to wall, cabinet or other appliance that extends beyond front edge of unit, 20" minimum clearance recommended to allow for optimum 140° door swing, providing complete crisper access and removal. (Absolute 3" minimum clearance will ONLY allow for 90° door swing which will provide limited crisper access with restricted removal.)
- To ensure optimum performance, do not install in areas where temperature drops below 55°F or rises above 110°F and avoid installing in direct sunlight or close proximity to range, dishwasher or other heat source.
- For proper ventilation, front grille MUST remain unobstructed.
- Recess electrical outlet when possible.
- Optional Ice Maker Kit (PN# IM116) available for installation in ice maker-ready models only.
- Water recess on rear wall recommended to prevent water line damage.
- Water Pressure - Cold water line must provide between 30 and 100 pounds per square inch (psi).
- Copper tubing with 1/4" O.D. recommended for water supply line with length equal to distance from rear of unit to household water supply line plus 7 additional feet. Optional Water Supply Installation Kits available.
- Adjustable front rollers to assist with door alignment.

OPTIONAL ACCESSORIES

- Ice Maker Kit - (PN# IM116).



FRIGIDAIRE

USA • 10200 David Taylor Drive • Charlotte, NC 28262 • 1-800-FRIGIDAIRE • frigidair.com
CANADA • 5855 Terry Fox Way • Mississauga, ON L5V 3E4 • 1-800-265-8352 • frigidair.ca

Note: For planning purposes only. Always consult local and national electric, gas and plumbing codes. Refer to Product Installation Guide for detailed installation instructions on the web at frigidair.com / frigidair.ca. Specifications subject to change. Accessories information available on the web at frigidair.com / frigidair.ca

FFTR2021T 10/17

© 2017 Electrolux Home Products, Inc.

FRIGIDAIRE

PROFESSIONAL.

PCFG3078AF

Available Colors : **Stainless Steel**

Version : **03/20**

Gas Ranges

30" Front Control Freestanding Air Fry Range



Product Specifications

Cooktop

Center	Simmer Oval (3000-15500 BTU)
Cooking Surface	Deep-Sump Formed Cooktop
Grate Color	Black Matte
Grate Material	Cast Iron
Grates	3 Continuous Grates
Knob Color	Stainless Steel
Knob Type	Cast Metal SS
Left Front	14000 BTU
Left Rear	9500 BTU
Right Front	18000 BTU
Right Rear	5000 BTU

Cooking Controls

Bake	Yes
Cancel	Yes
Display Type	Blue LED
Fast Preheat	Yes
Preheat	PowerPlus Preheat
Star-K® Certification	Yes

Dimensions: Exterior

Depth	26-6/8"
Depth (with Door 90° Open)	47"
Depth Including Handle	29"
Height	36-5/8"
Width	29-7/8"

Certifications & Approvals

ADA Compliant	Yes
ANSI Certified	Yes
Agency Approval	CSA
CSA Certified	Yes
CSA Listed	Yes
Sabbath Mode	Yes

General Specifications

Gas Supply Connection Location	Right Bottom Rear
Power Cord Included	Yes
Prop 65 Label	Yes

Controls

Auto Shut-Off	Yes
Control Location	Front Control

Oven

Bake	18000 BTU
Broil	13500 BTU
Oven 1 Convection System	True Convection - 900W
Oven 1 Interior Color	Slate Blue
Oven 1 Interior Depth	19-1/8"
Oven 1 Interior Height	20-7/8"
Oven 1 Interior Width	24-3/8"
Oven 1 Rack Configuration	1 Handle 1 Glide 1 Air Fry Tray Rack
Oven 1 Rack Positions	6 Positions

Exterior

Cooktop Finish	Stainless Steel
Drawer Finish	Smudge-Proof Stainless Steel
Handle Color	Stainless Steel

Drawer

Drawer Functionality	Storage
Handle	Stainless Steel

Capacities

Oven 1 Capacity	5.6
-----------------	-----

Electrical Specifications

Power Supply Connection Location	Left Rear Bottom
----------------------------------	------------------

Accessories

Griddle	Included
Probe	Red Probe Included

Note: For planning purposes only. Always consult local and national electric, gas and plumbing codes. Refer to Product Installation Guide for detailed installation instructions on the web at [frigidaire.com / frigidaire.ca](http://frigidaire.com/frigidaire.ca). Specifications subject to change. Accessories information available on the web at frigidaire.com / frigidaire.ca

FRIGIDAIRE

USA • 10200 David Taylor Drive • Charlotte, NC 28262 • 1-800-FRIGIDAIRE • frigidaire.com
 CANADA • 5855 Terry Fox Way • Mississauga, ON L5V 3E4 • 1-800-265-8352 • frigidaire.ca

FRIGIDAIRE

PROFESSIONAL

PCFG3078AF

Available Colors : Stainless Steel

Version : 03/20

Gas Ranges

30" Front Control Freestanding Air Fry Range

Installation Drawing

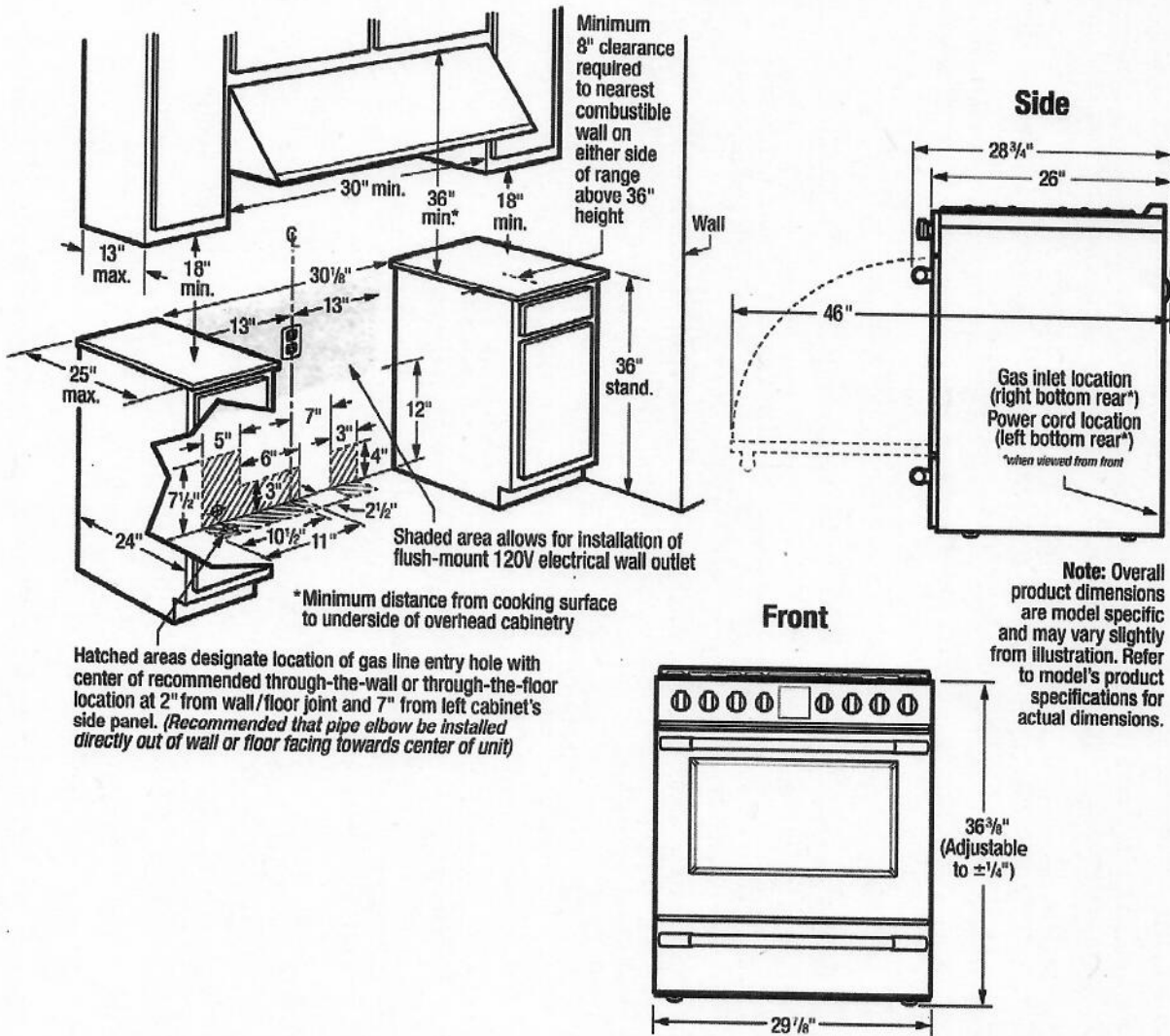

Note: Overall product dimensions are model specific and may vary slightly from illustration. Refer to model's product specifications for actual dimensions.

Note: For planning purposes only. Always consult local and national electric, gas and plumbing codes. Refer to Product Installation Guide for detailed installation instructions on the web at [frigidaire.com / frigidaire.ca](http://frigidaire.com/frigidaire.ca). Specifications subject to change. Accessories information available on the web at frigidaire.com / frigidaire.ca

ESSENTIALS

CYCLONE

UNDER-CABINET

Modern, clean lines provide a perfect complement to any interior, while centrifugal blowers liquefy cooking residue without complex filters to make clean up a snap. Available in black, white, stainless steel and black stainless finishes.

ZEPHYR

ZEPHYRONLINE.COM

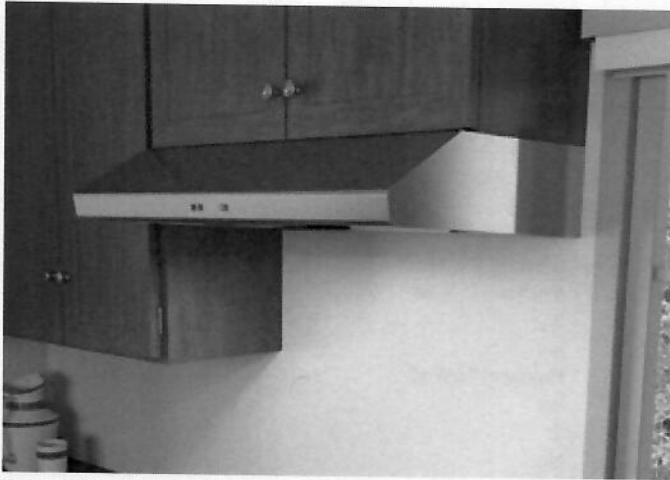

Stainless Steel

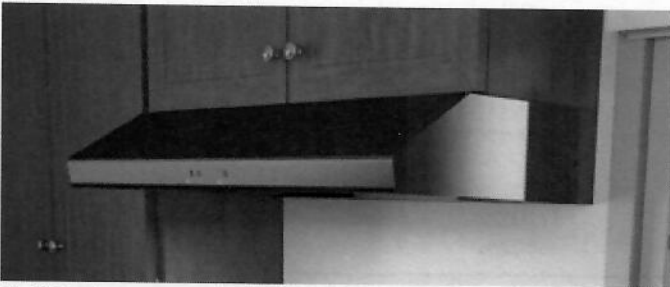

Black Stainless

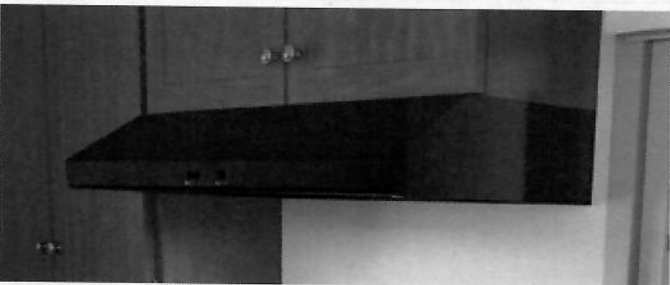

Black

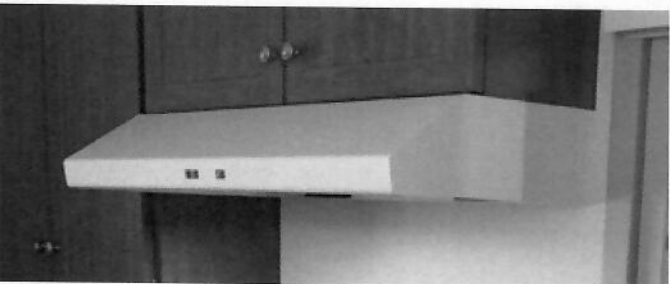

White

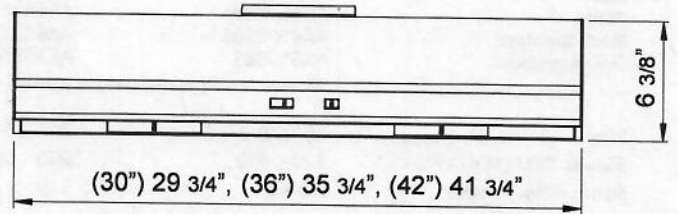

Front

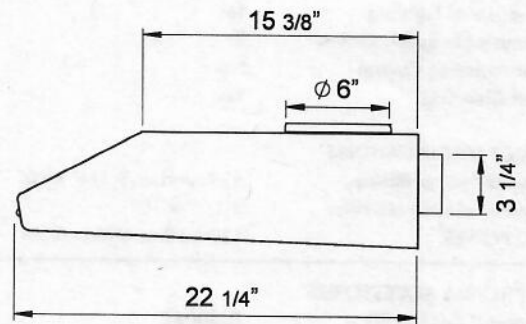

Side

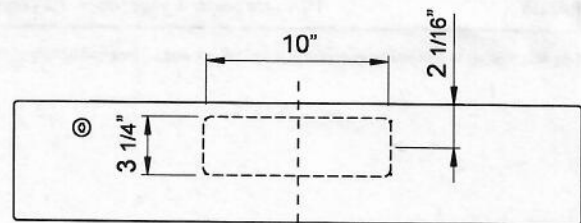

Back

ESSENTIALS

CYCLONE

UNDER-CABINET

ZEPHYR

ZEPHYRONLINE.COM

MODEL	AK6500BB	AK6536BB	AK6542BS
Black	AK6500BB	AK6536BB	
White	AK6500BW	AK6536BW	
Black Stainless	AK6500BBS	AK6536BBS	
Stainless Steel	AK6500BS	AK6536BS	AK6542BS
Size	30" (29-3/4")	36" (35-3/4")	42" (41-3/4")
Blower CFM (Min. - Max.)	290 - 600	290 - 600	290 - 600
Sones (Min. - Max.)	1.5 - 5	1.5 - 5	1.5 - 5
FEATURES			
Controls	Mechanical Slide	Mechanical Slide	Mechanical Slide
Speed Levels	3	3	3
Auto Delay-Off	No	No	No
Lighting	Halogen, 35W x2	Halogen, 35W x2	Halogen, 35W x2
Dual-Level Lighting	Yes	Yes	Yes
Removable Safety Grilles	2	2	2
Recirculating Option	No	No	No
Self Cleaning	Yes	Yes	Yes
DUCT SPECIFICATIONS			
Vertical Internal Blower	6" Round or 3-1/4" x 10"	6" Round or 3-1/4" x 10"	6" Round or 3-1/4" x 10"
Horizontal Internal Blower	3-1/4" x 10"	3-1/4" x 10"	3-1/4" x 10"
AC POWER	120V, 60Hz at Max. 2.4A	120V, 60Hz at Max. 2.4A	120V, 60Hz at Max. 2.4A
OPTIONAL ACCESSORIES			
Bloom™ GU10 LED	ZOB0040	ZOB0040	ZOB0040
Make-Up Air Kit	MUA006A	MUA006A	MUA006A
Damper, 6" Round	AK00066	AK00066	AK00066
MOUNTING HEIGHT RANGE*	24" - 32"	24" - 32"	24" - 32"
WARRANTY	10 years parts, 1 year labor	10 years parts, 1 year labor	10 years parts, 1 year labor

*Mounting height refers to distance between top of a 36" tall cooking surface and bottom of hood.



FRIGIDAIRE

PROFESSIONAL

Dishwasher

FPID2498SF

24" Built-In

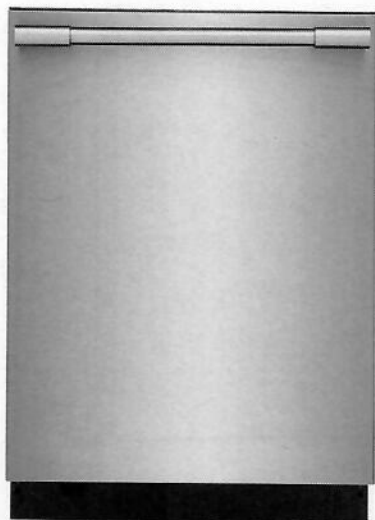

Signature Features

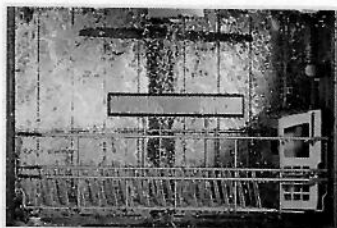

A Complete Clean

Clean dishes in one cycle with OrbitClean® Wash System, which uses four times more water coverage¹ for a complete clean.



Remarkable Dry

Dishes come out remarkably dry every time with EvenDry™².



A Place for Everything

Experience the ultimate flexibility of the SpacePro® Organization System. The third rack offers easy access and fits small cooking utensils, while the second rack adjusts to fit tall pots and pans.

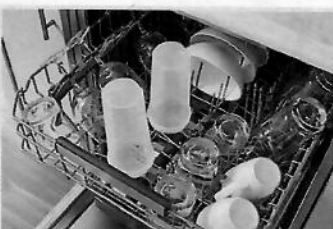

Cleans Hard-to-Reach Spots

Clean hard-to-reach spots with our PrecisionPro Wash Zones™ that target tough spots for the ultimate clean.

Product Dimensions

Height (Adjustable)	33-3/4" - 35-3/4"
Width	24"
Depth (Including Door)	24-1/4"

More Easy-To-Use Features

Powerful Clean, Fast

Get a powerful clean, fast with the best 30-minute clean³.

Smudge-Proof™

Resists fingerprints and cleans easily.

Know When Dishes Are Ready

Lets you know when dishes are complete when the blue LED light appears with PowerBright™ Floor Light.

Automatically Adjusts Cycles

DishSense™ Technology automatically adjusts the cycle time based on the level of clean that your dishes need for an efficient clean.

Efficient Water Usage

Cleans a full load of dishes using 15% less water⁴.

Consistent Cleaning Performance

For a consistent, reliable clean, our dishwasher has a removable stainless steel filter that prevents re-depositing of food particles.

Holds Up to 14 Place Settings

Clean up to 14 place settings in one cycle.

ENERGY STAR®

NSF® International Certification



Available in:

Stainless
(F)

¹Than a traditional spray arm.

²When used with rinse aid.

³Tested against competing models with comparable quick cycle times according to ANSI/AHAM DW-1-2010 with only 6 place settings.

⁴Over a year when using our normal cycle in a stainless tub compared to our plastic tub.

FRIGIDAIRE

PROFESSIONAL

Dishwasher

FPID2498SF 24" Built-In

Features

Control Design	Fully-Integrated Pro-Select®
Digital Display	Yes
Door Latch/Stay-Put Door Hinge Design	Yes/Yes
Low Rinse-Aid Indicator Light	Yes
Interior Design/Interior Color	Tall Tub/Stainless Steel
Wash System	Direct Feed
Wash Arm	OrbitClean®
Wash Levels/Wash Speeds	5/Variable
DishSense™ Technology	Yes
AquaSurge™ Technology	Yes
Sound Package	SilentDesign™
Filter/Filter Trap	S. Steel/Removable
Soft Food Disposer	
dB Level	47
Drying System	EvenDry™
Cycles	
Number of Cycles	7
PowerPlus™ (Heavy)	Yes
Normal	Yes
Light	
Quick Wash (30-Min.)	Yes
Favorite	Yes
China Crystal	Yes
Rinse Only	Yes
Energy Saver Plus	Yes
Upper Rack Wash Only	
Cycle Indicator Light/Control Lock	Yes/Yes
Cycle Complete Floor Beam Indicator	PowerBright™ LED
Options	
Heat/No Heat Dry	Yes
Hi-Temp Wash	Yes
NSF® Certified Sanitize Rinse	Yes
Delay Start	1-24 Hour
Rack System	
Rack Design	Deluxe
Rack Coating	Nylon TufRacks™
SpaceWise® Upper Rack -	
Rack Handles	Yes
Delicate-Care™ Soft Grips	Optional PN # 530-449-4157
Fold-Down Tines	Yes
Cup Shelves/Sterware Grips	2/6
Versa-Tray™	
Adjustable Rack Height	Yes
Lower Rack -	
SpaceWise® Silverware Basket	3-Piece Split
Fold-Down Tines	2 Full Rows
Small Items Cover	3
Third-Level Rack (Single Tray)	Yes
Certifications	
ENERGY STAR®	Yes
NSF® International Certification	Yes
Specifications	
Water Inlet Location	Bottom Left
Water Usage (Gallons)	4.0 - 8.0
Water Pressure (PSI)	20 - 90
Integral Air Gap on Supply	Yes
Leveling Legs	Yes
Power Supply Connection Location	Right Bottom Front
Voltage Rating	120V/60 Hz/15A
Connected Load (kW Rating) @ 120 Volts¹	1.44
Amps @ 120 Volts	15
Shipping Weight (Approx.)	75 Lbs.

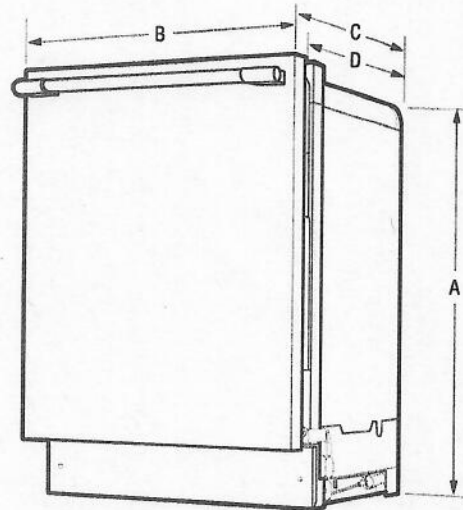

NOTE: For planning purposes only. Always consult local and national electric and plumbing codes. Refer to Product Installation Guide for detailed installation instructions on the web at frigidaire.com.



Product Dimensions

A - Height (Adjustable)	33-3/4" - 35-3/4"
B - Width	24"
C - Depth (Including Door)	24-1/4"
D - Depth (To Tub Flange)	22-1/2"
Depth with Door Open 90°	50-1/4"

¹For use on adequately wired 120V, dedicated circuit having 2-wire service with a separate ground wire. Appliance must be grounded for safe operation.

Cutout Dimensions

Height (Min.)	34"
Height (Max.)	35-3/4"
Width (Min.)	24"
Depth (Min.)	24"

Accessories information available on the web at frigidaire.com

FRIGIDAIRE

USA • 10200 David Taylor Drive • Charlotte, NC 28262 • 1-800-FRIGIDAIRE • frigidaire.com
 CANADA • 5855 Terry Fox Way • Mississauga, ON L5V 3E4 • 1-800-265-8352 • frigidaire.ca

FPID2498S 03/17

© 2017 Electrolux Home Products, Inc.

Specifications subject to change.

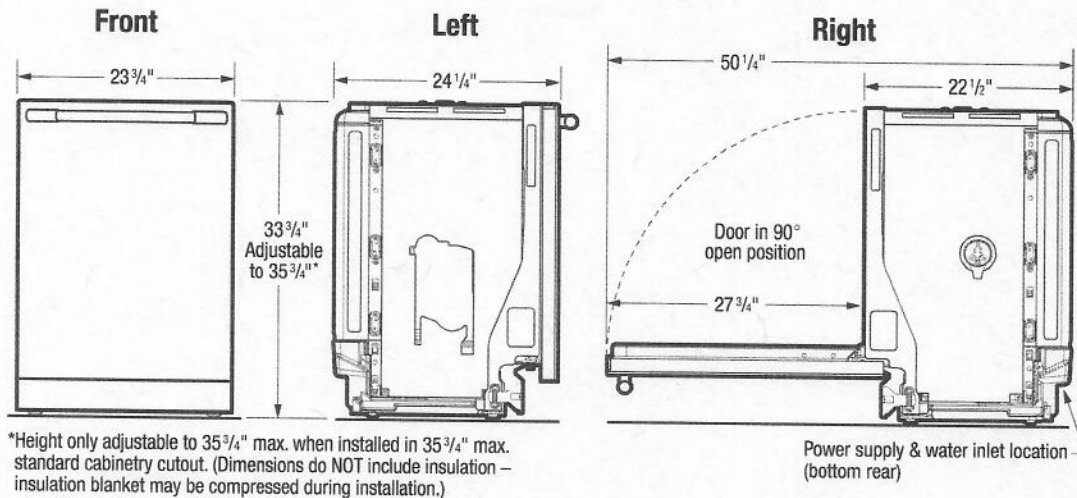

*Height only adjustable to 35 3/4" max. when installed in 35 3/4" max. standard cabinetry cutout. (Dimensions do NOT include insulation – insulation blanket may be compressed during installation.)

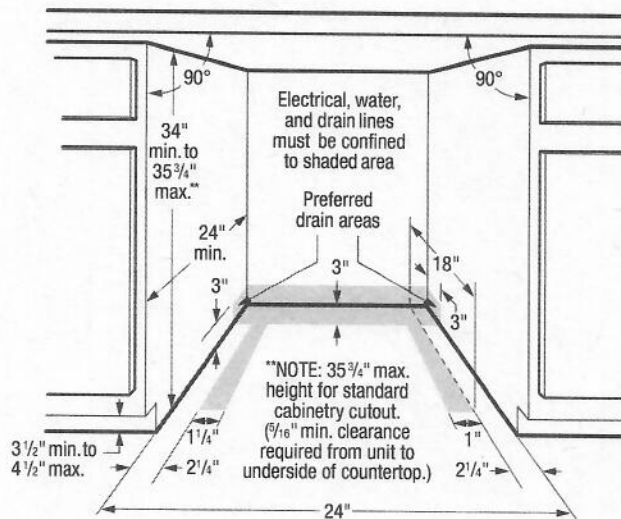

Dishwasher Specifications

- Product Shipping Weight (approx.) - 75 Lbs.
- Voltage Rating - 120V / 60 Hz / 15 Amps (maximum 20 Amps if connected with disposer)
- Connected Load (kW Rating) @ 120 Volts = 1.44kW (For use on adequately wired 120V, dedicated circuit having 2-wire service with a separate ground wire. Appliance must be grounded for safe operation.)
- Amps @ 120V = 15 Amps
- Always consult local and national electric & plumbing codes. Meets requirements of ASSE 1006 – integral air gap on supply.
- Water Pressure - Hot water line to dishwasher must provide between 20 and 90 pounds per square inch (psi) with at least 120° F hot water temperature.
- Make sure location has correct drain, water and electrical outlets to make connections – MUST be confined to shaded areas.
- Electrical and water supplies should enter cabinet opening on floor, or through back or side walls, as shown in shaded areas.
- If connecting drain hose to sink trap, local code may require installation of Air Gap Kit (not included).

- Leveling legs supplied to adjust height. (Note: Height only adjustable to 35-3/4" max. when installed in 35-3/4" max. standard cabinetry cutout. 5/16" min. clearance required from top of unit to underside of countertop. Dimensions do NOT include insulation – insulation blanket may be compressed during installation.)
- When installing adjacent to wall, cabinet or other obstruction that extends beyond front edge of unit, allow 2" minimum clearance between opened door and obstruction.
- Floor should be flat and free of obstructions with carpet removed to provide motor clearance.
- When installing at end of cabinet line, sides and back must be fully enclosed.
- Do not install unit under a cooktop, damage will occur.
- Recommended to seal cabinets, enclosing all sides of dishwasher, including underside of countertop, with oil-based paint or moisture-proof polyurethane to prevent possible steam/moisture damage.

Note: For planning purposes only. Refer to Product Installation Guide on the web at frigidaire.com for detailed instructions.

TOP LOAD WASHERS



TR3

TR5

TR7

TC5

Product Code	TR3003WN	TR5003WN	TR7003WN	TC5003WN
Available Colors	White	White	White	White
Capacity – Cu. Ft.	3.2	3.2	3.2	3.2
Stainless Steel Wash Tub	•	•	•	•
Porcelain Outer Tub	•	•	•	•
Preset Cycles	4	6	8	6
Preset Special Cycles			8	
Variable Speed, 1 HP Motor	•	•	•	
Two-Speed, ½ HP Motor				
Automatic Balancing System	•	•	•	•
Agitator	•	•	•	•
Durable 3 - Coat Finish	•	•	•	•
Prewash			•	
Load Size Selections	3	3	4	2
Temperature Selections	3	4	4	4
Soil Level Selections	2	2	4	2
Time Remaining Display			•	
End-of-Cycle Signal	•	•	•	•
Favorite Cycles			•	
Speed Cycle			•	
Delay Start			•	
Warranty	3-Year Parts & Labor	5-Year Parts & Labor	7-Year Parts & Labor	5-Year Parts & Labor
Model No.	AWN43RSN116TW01	AWN63RSN116TW01	AWNE9RSN116TW01	AWN632SP116TW02

Agency approvals: cULus

For the most accurate information, the installation guide should be used for all design and construction purposes. Due to continuous product improvements, design and specifications are subject to change without notice. The quality management systems of Alliance Laundry Systems are registered to ISO 9001.

Dimensions	W-Width	H-Height	D-Depth	Height with Lid Open
TR3003WN	25 5/8"	42 3/4"	28"	53"
TR5003WN	25 5/8"	42 3/4"	28"	53"
TR7003WN	25 5/8"	42 3/4"	28"	53"
TC5003WN	25 5/8"	42 3/4"	28"	53"

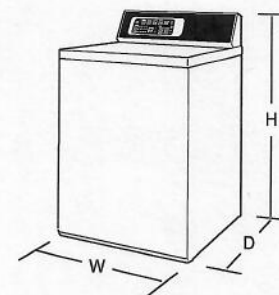

Optional Accessories

Drain Extension Kit – Part No: 204512

Hose Kit – Part No: 807239

Siphon Break Kit – Part No: 562P3

DRYERS

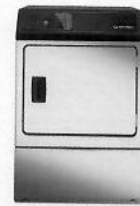

DR3

DR5

DR7

DF7

DC5

Product Code	Gas:	DR3000WG	DR5000WG	DR7000WG	DF7000WG (W) DF7000SG (SS)	DC5003WG
	Electric:	DR3000WE	DR5000WE	DR7000WE	DF7000WE (W) DF7000SE (SS)	DC5003WE
Available Colors		White	White	White	White or Stainless Steel	White
Capacity – Cu. Ft.		7.0	7.0	7.0	7.0	7.0
Galvanized Cylinder		•	•	•	• (White)	•
Stainless Steel Cylinder					• (Stainless)	
Preset Cycles		3	4	7	7	4
Moisture Sensor				•	•	
Auto Dry Cycles		2	3	4	4	3
220-CFM Exhaust		•	•	•	•	•
½ HP Motor		•	•	•	•	•
Temperature Selections		3	4	4	4	4
ADA Compliant		•	•	•	•	•
Cylinder Light		•	•	•	•	•
Anti-Wrinkle Cycle				•	•	
Reversible Door		•	•	•	•	•
Time Remaining Display				•	•	
End-of-Cycle Signal			•	•	•	•
Favorite Cycles				•	•	
Eco Cycle				•	•	
Control Location		Rear	Rear	Rear	Front	Rear
Warranty		3-Year Parts & Labor	5-Year Parts & Labor	7-Year Parts & Labor	5-Year Parts & Labor	5-Year Parts & Labor
Model No. (Gas)		ADG3SRGS115TW01	ADG4BRGS115TW01	ADGE9RGS115TW01	ADGE9BGS115TW01 (W) ADGE9BSS115TN01 (SS)	ADG4BRGS117TW01
(Electric)		ADE3SRGS175TW01	ADE4BRGS175TW01	ADEE9RGS175TW01	ADEE9BGS175TW01 (W) ADEE9BSS175TN01 (SS)	ADE4BRGS177TW01

For the most accurate information, the installation guide should be used for all design and construction purposes. Due to continuous product improvements, design and specifications are subject to change without notice. The quality management systems of Alliance Laundry Systems are registered to ISO 9001.

Dimensions	W-Width	H-Height	D-Depth	WSH-Work Surface Height	Depth with Door Open
DR3000WG/DR3000WE	26 7/8"	42 3/4"	28"	36"	51 1/2"
DR5000WG/DR5000WE	26 7/8"	42 3/4"	28"	36"	51 1/2"
DR7000WG/DR7000WE	26 7/8"	42 3/4"	28"	36"	51 1/2"
DF7000WG/DF7000WE (W) DF7000SG/DF7000SE (SS)	26 7/8"	40 1/16"	28"	40 1/16"	51 1/2"
DC5003WG/DC5003WE	26 7/8"	42 3/4"	28"	36"	51 1/2"

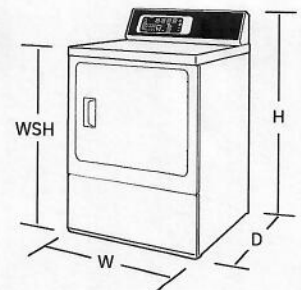

Optional Accessories

- Drying Rack – Part No: D512082
- Directional Exhaust Kit – Part No: 528P3
- Conversion Kit = Gas to LP – Part No: 649P3
- Flexible Metal Vent Kit – Part No: 521P3

Agency approvals: cULus, CSA us star, MA gas board

SHARP®

Carousel®



**1000
WATTS**

**1.4
CU.FT.**

Countertop Microwave Oven

SMC1442CS

ORVILLE REDENBACHER'S® CERTIFIED POPCORN PRESET TUNED FOR OPTIMAL POPPING RESULTS

PREMIUM BLUE LED DISPLAY

CONVENIENT "+30 SEC" KEY FOR INSTANT START

SENSOR COOK MENU FOR PRECISE COOKING AND REHEATING

12.8" CAROUSEL® TURNTABLE

EXPRESS COOK FOR ONE TOUCH COOKING UP TO 6 MINUTES



CONVENIENCE YOU CAN COUNT ON

This family-sized 1.4 cu. ft.* microwave is more than a great choice for reheating and everyday cooking. It's also specifically tuned to achieve optimal popping results from the leader in microwave popcorn, Orville Redenbacher's®. Simply touch the "Popcorn" button to choose the Classic Size (3.3 oz) or Single Serve Mini Bag (1.16 oz) of Orville Redenbacher's® Microwave Popcorn. Then sit back and enjoy light and fluffy popcorn with the delicious, buttery flavor of Orville Redenbacher's® Gourmet® Popping Corn.

The SMC1442CS is not just for popcorn. 1000 watts of power give you rapid reheating and fast cooking. Easy-to-clean modern, brushed stainless steel finish to complement your style. One-Touch controls, Auto Defrost and the Carousel turntable system make cooking and reheating faster and easier. It's easy to see why home cooks throughout the world trust Sharp Carousel.

SPECIFICATIONS

DESIGN

Cabinet Color:	Silver
Door Color:	Stainless Steel
Control Type:	Touch Control
Control Panel Color:	Black
Display:	Blue LED

FEATURES

Capacity (cu. ft.):	1.4*
Watts:	1000
Cooking Power Levels:	10
Turntable Type:	Removable
Turntable Diameter (Inches):	12.8"
Turntable Material:	Glass
Defrost by Time:	Yes
Auto Defrost:	Meat, Poultry, Seafood
One Touch Cook:	Beverage, Popcorn
Sensor Cook:	Potato, Frozen Entree, Frozen Vegetables, Sensor Reheat
Soften Functions:	Butter, Chocolate, Ice Cream, Cream Cheese
Plus Cooking Time (+30 sec):	Yes
Time Cook:	Yes

Express Cook:	Yes (1-6 mins)
Clock/Timer:	Yes
Child Safety Lock:	Yes

DIMENSIONS & WEIGHT (in./lbs.)

Cavity Dimensions (w x h x d):	15.4" x 10.0" x 15.4"
Product Dimensions (w x h x d):	21.3" x 12.4" x 16.1"
Shipping Dimensions (w x h x d):	24.5" x 15.1" x 18.4"
Product Weight / Shipping Weight:	32.8 lbs. / 36.8 lbs.

ADDITIONAL SPECIFICATIONS

Power Source / Ratings:	AC 120V, 60Hz
Safety Compliance:	UL®

WARRANTY/UPC

Parts & Labor:	1 year limited
Magnetron Tube:	Additional 4 years (part only)
UPC:	074000620148

© 2017 Sharp Electronics Corporation. All rights reserved.

Sharp, Carousel and all related trademarks are trademarks or registered trademarks of Sharp Corporation and/or its affiliated companies. All other trademarks are property of their respective owners.

Product specifications and design are subject to change without notice.

Orville Redenbacher's® is a registered trademark of Conagra Foods RDM, Inc., used under license. Popcorn not included.

SHARP ELECTRONICS CORPORATION
100 Paragon Drive, Montvale, NJ 07645
1.800.BE.SHARP • www.sharpsusa.com

03-29-2017 v1

*Internal capacity calculated by maximum width, depth & height. Actual capacity for holding food is less.

**2015 retail sales data from Information Resources, Inc.



BID FORM

Appliances

Fire Station 48, 4228 Airport Blvd, Arlington WA 98223

Bids Due: 2:00 pm, April 12, 2021

Invitation for Bid: Appliances – Fire Station 48

The bid submitted on this bid form is for the above referenced Invitation for Bid and is submitted in full knowledge and agreement with the terms and conditions contained in the Invitation for Bid. For this bid to be accepted as valid, this bid must be signed by an authorized person and any data requested in the Invitation for Bid, must be included at time of bid submission.

Bid prices exclude Washington State Sales Tax. Washington State Sales Tax 9.2% shall be added as appropriate on submitted invoices.

The quantities included on this bid form are for bid evaluation purposes only, it is not a guarantee of quantities to be ordered.

Item	Qty	Unit	Price
Dishwasher – Frigidaire Professional FDIP2498SF, 24” Built-In, Stainless Steel	2	ea	\$
Microwave – Sharp Carousel Countertop SMC1442CS, Stainless Steel	3	ea	\$
Washer – Speed Queen TR3003WN Top Load, White	1	ea	\$
Dryer – Speed Queen DR3000WG, Gas, White	1	ea	\$
Range – PCFG3078AF, Gas, 30” Front Control Freestanding Air Fry Range, Stainless Steel	1	ea	\$
Exhaust Hood – AK6500BS, Zephyr Essentials Cyclone Under-Cabinet, 30” Stainless Steel	1	ea	\$
Refrigerator – FFTR2021T D/S/W/B, Top Mount, 20.4 cu ft, Stainless Steel	1	ea	\$
Refrigerator - Frigidaire FPBG2278UF, French Door Counter-Depth, 22.3 cu ft, Stainless Steel	3	ea	\$
TOTAL BID			\$

SPECIAL CONDITONS:

By signing below the undersigned certifies they are authorized to submit a bid on behalf of the business listed and agree to furnish and deliver the items listed herein for the above price per the terms and conditions contained in the above referenced Invitation for Bid.

SIGNATURE: _____

DATE: _____

NAME (print): _____

PHONE: _____

BUSINESS NAME: _____

EMAIL: _____

ADDRESS: _____

BIDDER CHECKLIST: ____ MRSC ROSTER: ____

CITY OF ARLINGTON
PURCHASE ORDER TERMS AND CONDITIONS - GOODS

VENDOR AND PURCHASER AGREE AS FOLLOWS:

1. DEFINITIONS -

CITY - City of Arlington

PURCHASER – The identified City of Arlington Employee(s) and Departments who have been authorized to procure goods on behalf of the City

VENDOR – Person(s) or entity referenced in this Purchase Order for supplying the City with goods or merchandise.

GOODS - Items of merchandise, finished products, supplies, or raw materials.

2. DELIVERY. For any exception to the delivery date as specified on this order, Vendor shall give prior notification and obtain written approval thereto from the appropriate City representative with respect to delivery under this order. Time is of the essence and the order is subject to termination and/or appropriate damages for failure to deliver as specified. Acceptance by the Purchaser of late performance with or without objection or reservation shall not waive the right to claim damage for such breach nor constitute a waiver of the requirements for the timely performance of any obligation remaining to be performed by Vendor.

3. PACKAGING. No charge will be allowed for packaging, boxing, or handling costs except as specified on this order.

4. SHIPPING INSTRUCTIONS. Unless otherwise specified, all goods are to be shipped prepaid

F.O.B. Destination. Where shipping addresses indicate room numbers, the Vendor shall make delivery to that location at no additional charge where specific authorization is granted to ship goods F.O.B. shipping point. Vendor agrees to prepay all shipping charges, route as instructed or if instructions are not provided, route by cheapest common carrier and to bill the Purchaser as a separate item on the invoice for said charges. Each invoice for shipping charges shall contain the original or a copy of the bill indicating that the payment for shipping has been made. Purchaser reserves the right to refuse COD shipments.

5. RISK OF LOSS. Regardless of F.O.B. point, Vendor agrees to bear all risks of loss, injury or destruction of goods and materials ordered herein which occur prior to delivery. Such loss, injury or destruction shall not release Vendor from any obligations hereunder.

6. CHANGES. No alteration in any of the terms, conditions, delivery price, quantity, quality, or specifications of this order will be effective without written consent of the Purchaser for its acceptance prior to shipment.

7. SAVE HARMLESS. Vendor shall protect, indemnify and save Purchaser, its officers, agents, servants and employees harmless from and against damage, cost or liability of any nature for any injuries to persons or property arising from acts or omissions of Vendor, and Vendor's employees, agents, or subcontractors, howsoever caused.

8. INFRINGEMENTS. Vendor agrees to protect and save harmless the Purchaser against all claims, suits or proceedings because of use of copyrighted, or un-copyrighted composition, secret process, patented or unpatented invention, articles or appliances furnished or used under this order, and to assume all expenses and damages arising from such claims, suits, or proceedings.

9. REJECTION. All goods or materials purchased herein are subject to approval by the Purchaser. Any rejection of goods or material resulting because of nonconformity to the terms and specifications of this order whether held by the Purchaser or returned, will be at Vendor's risk and expense.

10. ASSIGNMENTS. The provisions or monies due under this contract shall only be assignable, in whole or in part, with the proper written approval of the CFO or approved representative of the City of Arlington.

11. PAYMENTS, CASH DISCOUNTS, LATE PAYMENT CHARGES. Invoices will not be processed for payment nor will the period of computation for cash discount commence until receipt of a properly completed invoice or invoice items, whichever is later. If an adjustment in payment is necessary due to damage or dispute, the cash discount period shall commence on the date final approval for payment is authorized. The City's standard terms are net 30 days from date of receipt of invoice.

12. WARRANTIES. Vendor warrants that articles supplied under this order conform to specifications herein and are fit for the purpose for which such goods are ordinarily employed, except that if a particular purpose is stated, the material must then be fit for that particular purpose.

13. FORCE MAJEURE. Neither party shall be held responsible for failure or delay in the fulfillment of conditions of this contract or purchase order if the cause is not within the control of the party whose performance is interfered with and which, by the exercise of reasonable diligence, said party is unable to prevent.

14. GRATUITIES. The Purchaser may, by written notice to the Vendor, cancel this contract if it is found by Purchaser that Vendor or any agent or representative of Vendor, offered or gave gratuities, in the form of entertainment, gifts or otherwise, to any officer or employee of the City of Arlington with a view toward securing a contract or securing favorable treatment with respect to the awarding of this contract.

15. TAXES. Unless otherwise indicated, the Purchaser agrees to pay all State of Washington salesor use tax. Vendor shall comply with and be responsible for all federal, state, and local taxes andlicensing requirements. When applicable, Purchaser agrees to furnish Vendor, upon acceptance ofarticles supplied under this order, with an exemption certificate.

16. TERM. This order is valid for the current year only if noted on this purchase order, services or goods which have not been delivered by December 31 of the current year shall be considered canceled without further notice. Reinstatement of the order shall only occur upon written approval of the CFO or approved representative of the City.

17. TERMINATION. In the event of a breach by Vendor of any of the provisions of this contract, the Purchaser reserves the right to cancel and terminate this contract forthwith upon giving an oral or written notice of the Vendor. Vendor shall be liable for damages suffered by the Purchaser resulting from Vendor's breach of contract.